



STAMPAGGIO METALLI A FREDDO
COLD METAL FORMING

Finali per marmitta Silencer end piece

modello/model

S

Finali per marmitta interamente in AISI 304
senza saldature, con finitura a specchio,
completi di fascetta zincata bianca

*End pieces for silencers made entirely
of AISI 304 weldless, with mirror finish,
complete with white zinc-plated clamp*

materiale/material

Acciaio Inox + Acciaio (fascetta)
Stainless Steel + Steel (clamp)

trattamento/treatment

Zincatura CrIII - tipo II (fascetta)
Zinc-plating CrIII - II (clamp)

Ø nominale/nominal Ø

da 40 a 60
from 40 to 60

vite/screw

M8



forza serraggio/torque

-

Normativa/norm

Conforme 2000/53/CE+RoHS
2000/53/EC+RoHS compliant



COD.	Pack*	A	ØD ¹	ØE	COD.	Pack*	A	ØD ¹	ØE
S 115 76 40 XA	2	115	40	76	S 175 76 40 XA	2	175	40	76
S 115 76 42 XA	2	115	42	76	S 175 76 42 XA	2	175	42	76
S 115 76 45 XA	2	115	45	76	S 175 76 45 XA	2	175	45	76
S 115 76 48 XA	2	115	48	76	S 175 76 48 XA	2	175	48	76
S 115 80 50 XA	2	115	50	80	S 175 80 50 XA	2	175	50	80
S 115 80 52 XA	2	115	52	80	S 175 80 52 XA	2	175	52	80
S 115 80 55 XA	2	115	55	80	S 175 80 55 XA	2	175	55	80
S 115 80 57 XA	2	115	57	80	S 175 80 57 XA	2	175	57	80
S 115 80 60 XA	2	115	60	80	S 175 80 60 XA	2	175	60	80
S 150 76 40 XA	2	150	40	76	S 220 76 40 XA	5	220	40	76
S 150 76 42 XA	2	150	42	76	S 220 76 42 XA	5	220	42	76
S 150 76 45 XA	2	150	45	76	S 220 76 45 XA	5	220	45	76
S 150 76 48 XA	2	150	48	76	S 220 76 48 XA	5	220	48	76
S 150 80 50 XA	2	150	50	80	S 220 80 50 XA	5	220	50	80
S 150 80 52 XA	2	150	52	80					
S 150 80 55 XA	2	150	55	80					
S 150 80 57 XA	2	150	57	80					
S 150 80 60 XA	2	150	60	80					

*Conf./Pack 2 = Astuccio singolo, 5 = Sfusi / 2 = Single box, 5 = loose

¹ØD È il diametro nominale da stringere / It is nominal diameter to tighten

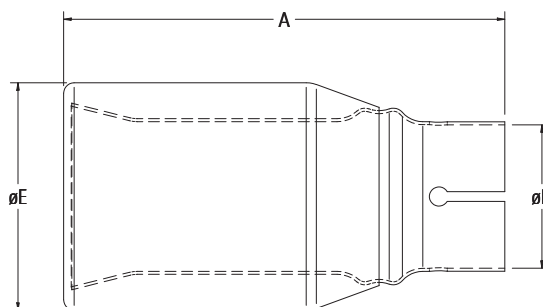

misure in/measures in: mm

B e B di Bazzani Francesca e Bazzani Filippo snc / Via F. Borromini 1, Loc. Sambuca 50028 Tavarnelle Val di Pesa (FI) Italia
Tel +39 055 80.71.591 / Fax +39 055 80.71.259 / E-mail: info@bebweb.it / Web-site: www.bebweb.it
Organizzazione con sistema di gestione certificato UNI EN ISO 9001 / Organization with certified system of management UNI EN ISO 9001

© B e B di Bazzani Francesca e Bazzani Filippo snc / Le informazioni riportate nel presente documento sono a titolo indicativo. L'azienda si riserva il diritto di apportare modifiche senza preavviso. The information contained in this document is purely indicative. The company reserves the right to introduce changes without prior notice.

S - Rev. A



SGS
SINCERT